

## Testing of Long Fiber-Reinforced Composites

testXpo 2018  
Helmut Fahrenholz, Zwick

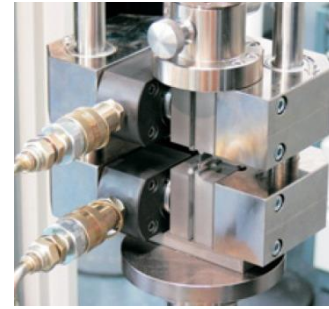

**Applications of advanced composites**

**The supply chain**

**Test methods**

**Testing machines and instruments**

# Applications

For many years Zwick testing equipment has been frequently used for testing of advanced composites.



Aerospace



Automotive



Biomedical



Leisure



Aircraft



Sport



Infrastructure / Building



Energy

Applications of advanced composites

The supply chain

Test methods

Testing machines and instruments

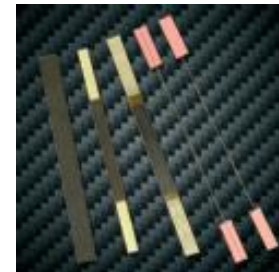
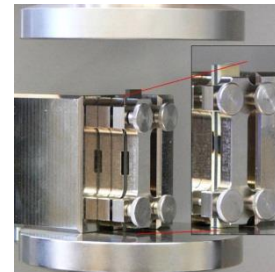

# The testing pyramid

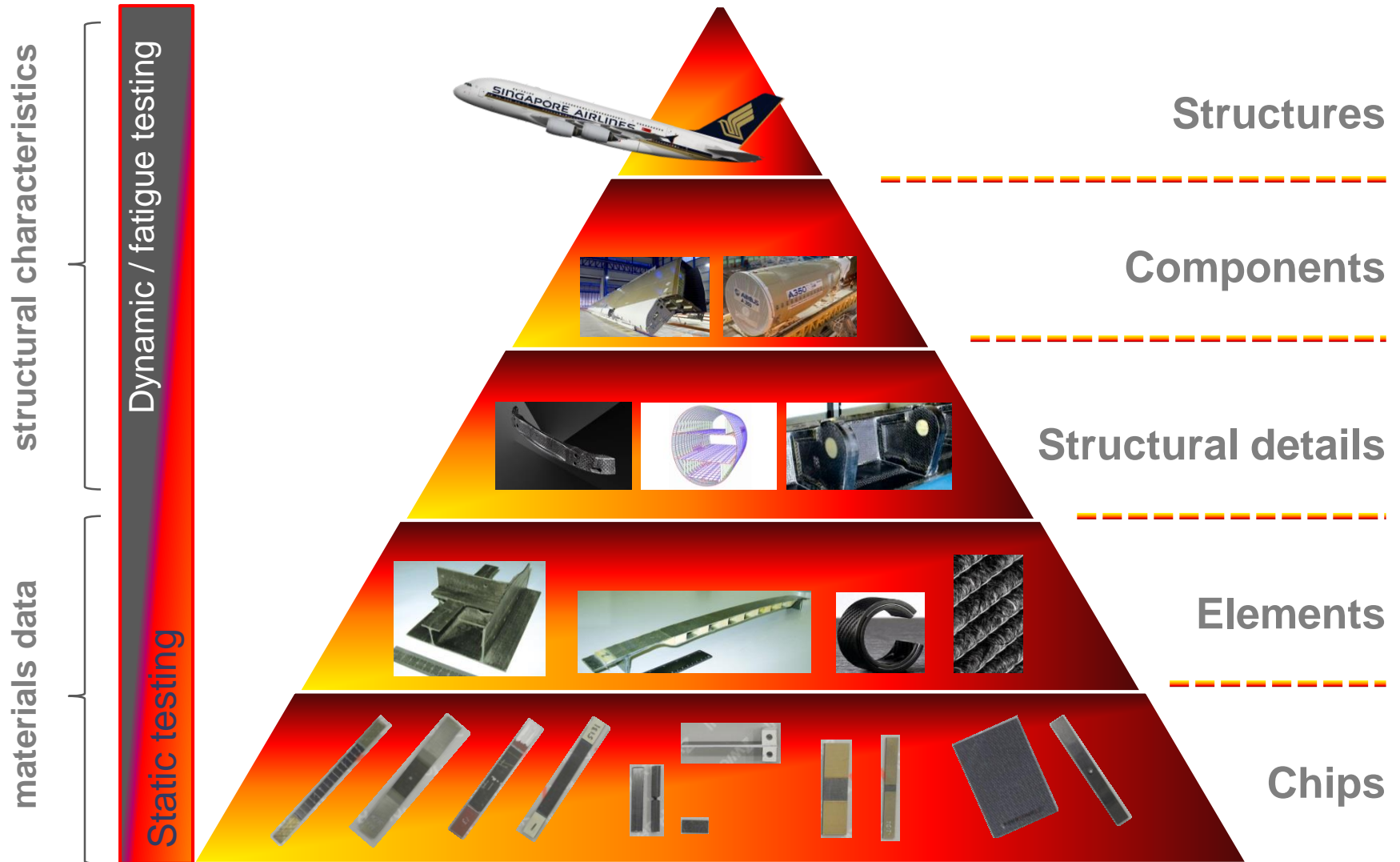

Zwick covers all types of mechanical testing and thus more than 150 standards in the testing of advanced composites.

- **Tensile**
- Open hole and filled hole tensile
- Compression after impact
- Interlaminar shear strength
- Lap shear
- Rail shear
- Bearing strength
- Fracture mechanics
- Impact
- Hardness
- Creep
- Plain compression
- Open hole and filled hole compression
- Flexural tests
- In-plane shear
- V-notch beam shear (Iosipescu)
- Shear tests on plane specimens
- Fasteners testing
- Fatigue testing
- HDT

Unidirectional laminates are tested parallel to the direction of the fiber (0°) or perpendicular to the fiber direction (90°).

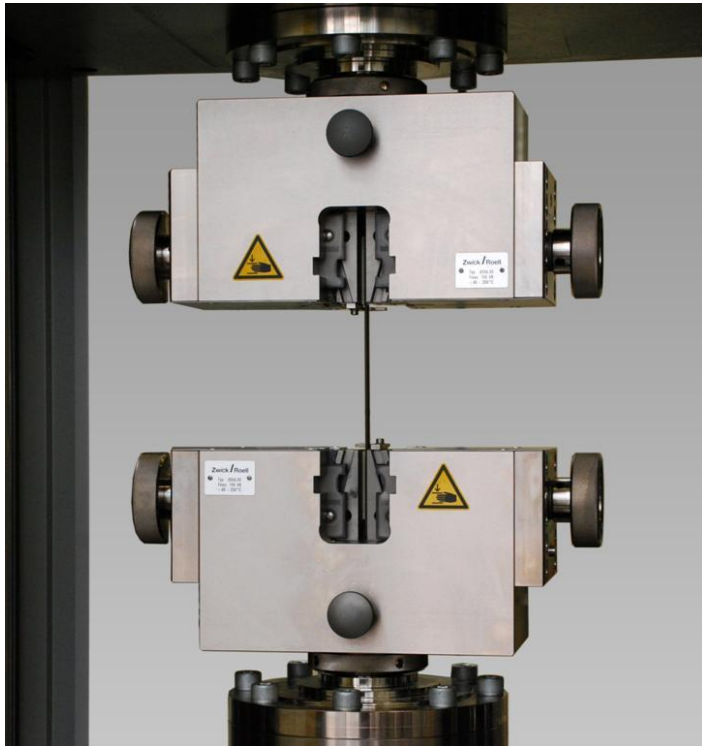

- Specimens are normally equipped with tabbed ends
- Alignment is important and can be checked by specimen that are instrumented with 3 or more strain gages
- Strain measurement available with Zwick:
  - strain gages
  - mechanical single sided extensometers
  - mechanical double sided averaging extensometers
  - optical extensometers (Video, Laser-Speckle)
- Tensile modulus is a cross-section related chord modulus (ASTM, ISO) or a secant modulus related to the fiber (EN)
- Poisson's ratio is typically determined
- DIN 65469 describes a method to test single layer prepregs after curing.

ISO 527-4	ASTM D 4018	EN 2561	EN 2747	ASTM D 3039	ASTM D 5083	DIN 65378	Airbus AITM 1.0007	Boeing BSS 7320	SACMA SRM 4R-94	TR 88012 CRAG meth. 300-303
ISO 527-5	ISO 11566	EN 2597	prEN 6035	ASTM D 3916	ASTM D 7205	DIN 65469	DIN 29971		SACMA SRM 9 - 94	

Multidirectional laminates are typically tested with larger specimen.



Specimen dimensions acc. ISO 527	Multidirectional	Unidirectional
Overall length, $L_3$	250 mm	250 mm
thickness, $h$	<b>2 to 10 mm</b>	<b>1 or 2 mm</b>
Width, $b_1$	<b>25 or 50 mm</b>	<b>15 or 25 mm</b>
Distance between tabs	150 mm	150 mm
Grip separation	136 or 150	136 mm
Gage length, rec.	50 mm	50 mm

Specimen 15 mm large



Hydraulic grip for ambient and temperature chamber

<b>ISO 527-4</b>	<b>ASTM D 4018</b>	<b>EN 2561</b>	<b>EN 2747</b>	<b>ASTM D 3039</b>	<b>ASTM D 5083</b>	<b>DIN 65378</b>	<b>Airbus AITM 1.0007</b>	<b>Boeing BSS 7320</b>	<b>SACMA SRM 4R-94</b>	<b>TR 88012 CRAG meth. 300-303</b>
<b>ISO 527-5</b>	<b>ISO 11566</b>	<b>EN 2597</b>	<b>prEN 6035</b>	<b>ASTM D 3916</b>	<b>ASTM D 7205</b>	<b>DIN 65469</b>	<b>DIN 29971</b>		<b>SACMA SRM 9 - 94</b>	



## Single filament carbons and graphite fiber tows ....

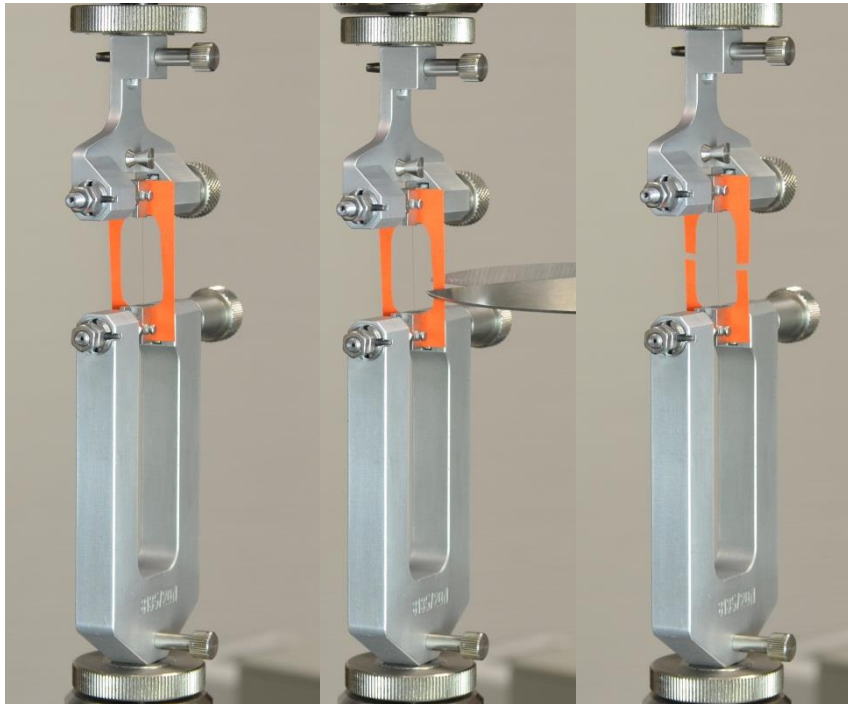

- Specimens can be tested untabbed if the type of clamping produces valid fracture type, but are normally equipped with tabbed ends
- A uniform impregnate resin is applied to the fiber prior to testing
- Tensile strength and tensile modulus as well as the failure mode are recorded



ISO 527-4	<b>ASTM D 4018</b>	EN 2561	EN 2747	ASTM D 3039	ASTM D 5083	DIN 65378	Airbus AITM 1.0007	Boeing BSS 7320	SACMA SRM 4R-94	TR 88012 CRAG meth. 300-303
ISO 527-5	<b>ISO 11566</b>	EN 2597	prEN 6035	ASTM D 3916	ASTM D 7205	DIN 65469	DIN 29971		SACMA SRM 9 - 94	

# Open hole and filled hole tensile

The effect of holes and bolts on composites can be tested by comparing the tensile behavior of plain specimen with those having an open hole or a bolted hole. The ratio is called “notch factor, K”

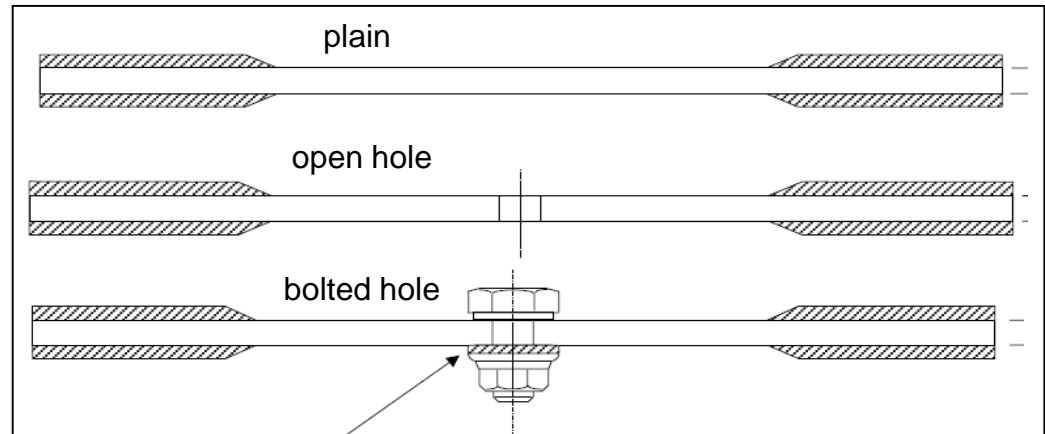
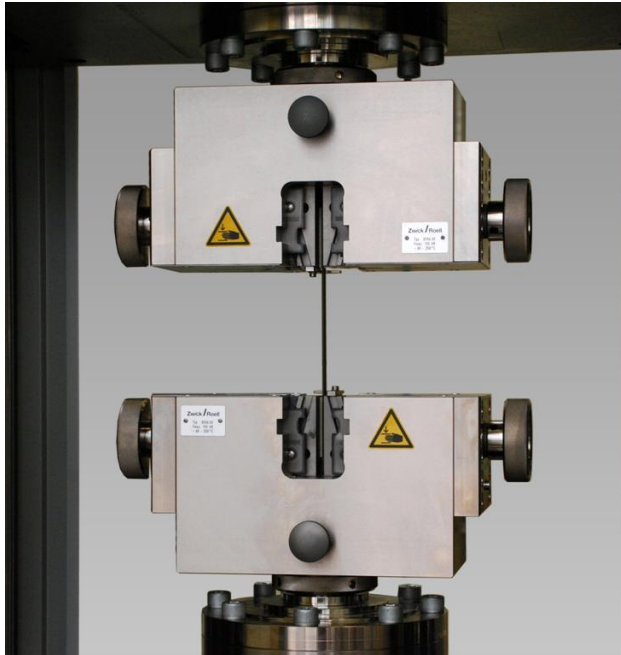

Plain, open hole and filled hole specimen acc. to Airbus's AITM standard are 32 mm large and have a clamp distance of 180 mm.

Stress calculations always consider the plain cross section, not taking into account the reduction by the hole.

<b>ASTM D 5766</b> <b>(OHT)</b>	<b>ASTM D 6742</b> <b>(FHT)</b>	<b>Airbus AITM</b> <b>1.0007</b>	<b>SACMA SRM</b> <b>5-94</b>	<b>NASA RP</b> <b>1092 ST-3</b>			
------------------------------------	------------------------------------	-------------------------------------	---------------------------------	------------------------------------	--	--	--

Zwick covers all types of mechanical testing and thus more than 150 standards in the testing of advanced composites.

- Tensile
- Open hole and filled hole tensile
- Compression after impact
- Interlaminar shear strength
- Lap shear
- Rail shear
- Bearing strength
- Fracture mechanics
- Impact
- Hardness
- Creep
- Plain compression
- Open hole and filled hole compression
- Flexural tests
- In-plane shear
- V-notch beam shear (Iosipescu)
- Shear tests on plane specimens
- Fasteners testing
- Fatigue testing
- HDT

# Plain Compression

Bending and buckling shall be avoided in compression tests. Even though several compression tools have been proposed by standards, the tests can be divided into “end-loading” and “shear-loading”.

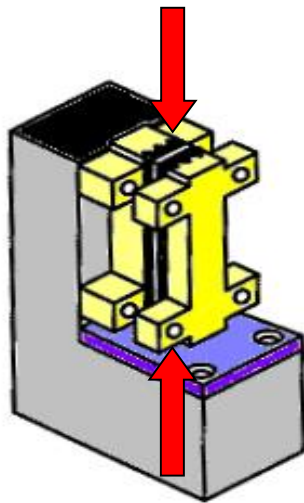

End Loading configuration

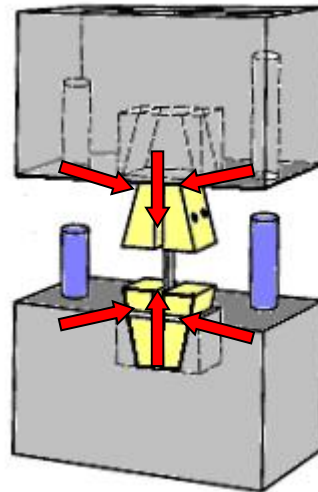

Shear Loading configuration

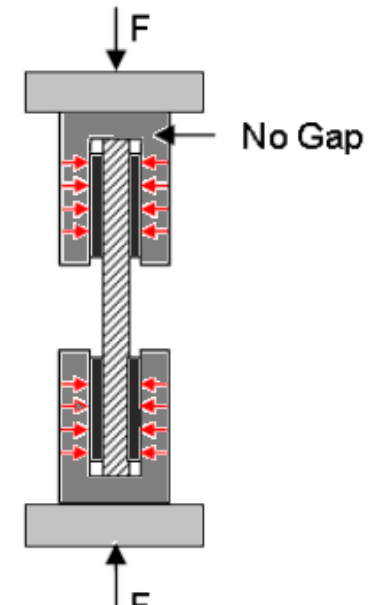

Combined Loading configuration

<i>ISO 14126</i>	<i>ISO 604</i>	<i>ASTM D 3410</i>	<i>ASTM D 695</i>	<i>ASTM D 6641</i>	<i>DIN 65375</i>	<i>JIS K 7076</i>
<i>prEN 2850</i>	<i>AITM 1-0008</i>	<i>Boeing BSS 7260 - type III and IV</i>	<i>SACMA SRM 1R-94</i>	<i>RAE-TR 88012 CRAG Method 400</i>	<i>RAE-TR 88012 CRAG Method 401</i>	

# Plain Compression

End-loading compression tools are variants of the ASTM D 695 tool, initially developed for plastics testing.

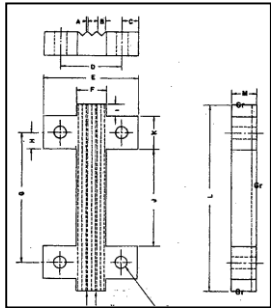

ASTM D 695 tool for plastics. (not used for composites)

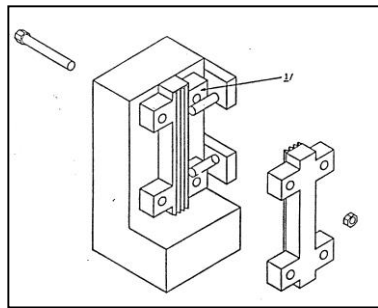

The “ASTM D 695-Boeing modified” tool for composites includes a support and lateral end-stops to place the tool exactly upright and to improve handling.

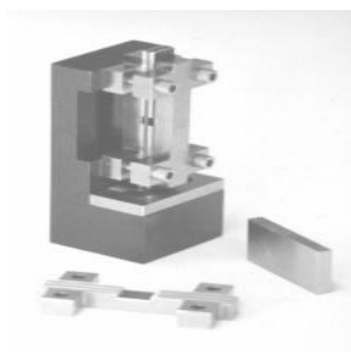

SACMA introduced this tool with grooves for the strain gages to perform modulus measurements

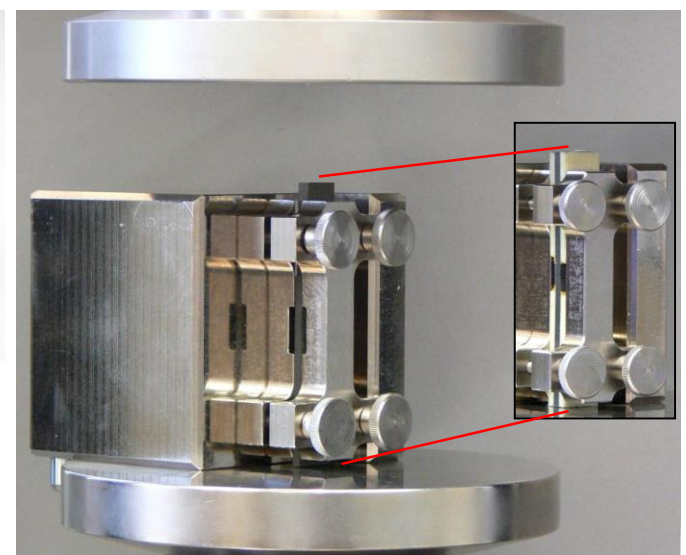

Zwick's compression tool includes guides for both, Modulus (center) and Ultimate Strength (right) measurement. It is always well centered to the machine.

<i>ISO 14126 meth. 2</i>	<i>ISO 604</i>	<i>ASTM D 3410</i>	<i>ASTM D 695</i>	<i>ASTM D 6641</i>	<i>DIN 65375</i>	<i>JIS K 7076</i>
<i>prEN 2850 type B</i>	<i>AITM 1-0008</i>	<i>Boeing BSS 7260 - type III and IV</i>	<i>SACMA SRM 1R-94</i>	<i>RAE-TR 88012 CRAG Method 400</i>	<i>RAE-TR 88012 CRAG Method 401</i>	

Shear loading tools use conventional clamping principles known from tension testing. Several improvements have been applied from the simple early Celanese tool to today's new HCCF fixture.

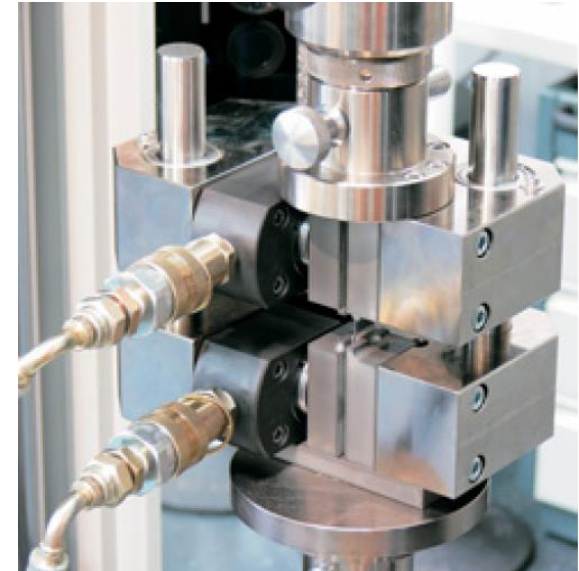
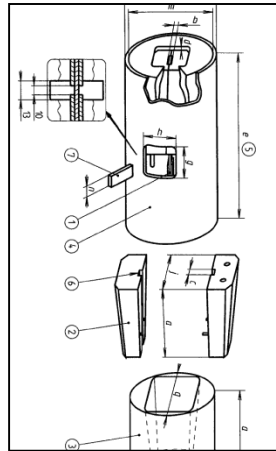

The former ASTM D 3410 tool was equipped with conical wedges. Therefore it was sensitive to the specimen thickness and to torsion forces.

Former DIN 65380 and prEN 2850 proposed modified Celanese tools with flat wedges to solve the problem of specimen thickness (left). The IITRI developed a similar tool with two guides to overcome the torsion problem (right).

HCCF performs the IITRI function, but with significantly improved handling

<b>ISO 14126 meth. 1</b>	<b>ISO 604</b>	<b>ASTM D 3410</b>	<b>ASTM D 695</b>	<b>ASTM D 6641</b>	<b>DIN 65375</b>	<b>JIS K 7076</b>
<b>prEN 2850 type A</b>	<b>AITM 1-0008</b>	<b>Boeing BSS 7260 - type III and IV</b>	<b>SACMA SRM 1R-94</b>	<b>RAE-TR 88012 CRAG Method 400</b>	<b>RAE-TR 88012 CRAG Method 401</b>	

# Plain compression, loads up to 250 kN

“Combined Shear and End loading” is described in several standards. The HCCF fixture allows comfortable and accurate adjustment of the shear loading portion.

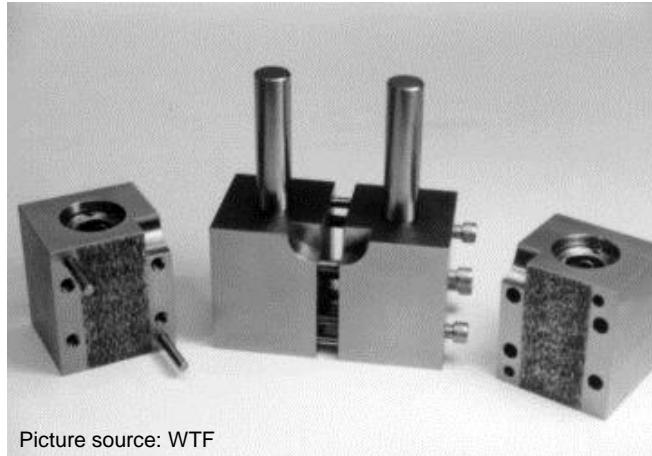
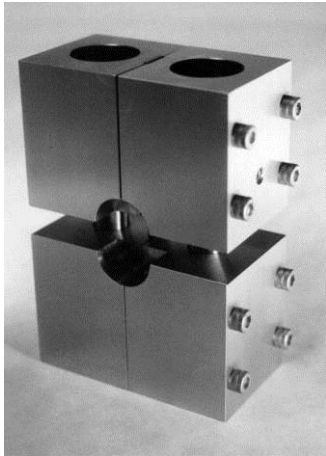

Picture source: WTF

Mechanical combined loading tools adjust the clamping force by the bolt torque. Stiff column-type guides allow exact axial alignment throughout the test. The gage length can simply be adjusted by the overall specimen length. But the handling remains time consuming and the application of the shear load laborious.

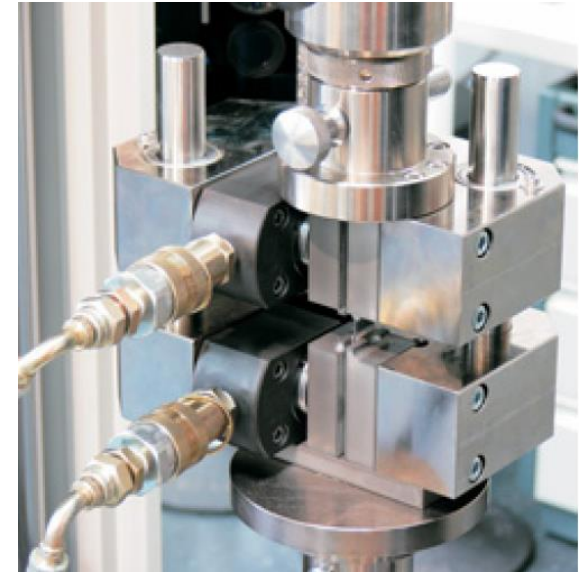

HCCF performs combined loading, but with significantly improved handling.

<i>ISO 14126 meth. 2</i>	<i>ISO 604</i>	<i>ASTM D 3410</i>	<i>ASTM D 695</i>	<i>ASTM D 6641</i>	<i>DIN 65375</i>	<i>JIS K 7076</i>
<i>prEN 2850</i>	<i>AITM 1-0008</i>	<i>Boeing BSS 7260 - type III and IV</i>	<i>SACMA SRM 1R-94</i>	<i>RAE-TR 88012 CRAG Method 400</i>	<i>RAE-TR 88012 CRAG Method 401</i>	

# Plain Compression, high load

Compression tests at high loads are performed in combined loading. Guided hydraulic grips are approved for forces up to 600 kN.

- Airbus AITM defines the specimen type A3, which is designed for compression loads up to 500 kN
- The specific design of the gripping inserts allows soft load introduction and thus avoids peak stresses.
- Perfect alignment, meeting the AITM standard, is achieved by four supplementary guiding columns
- These grips can be used for tensile testing as well
- Temperature range from -60°C to 350 °C is available.
- Operation in shear loading and in combined loading



Laterally guided hydraulic gripping system for up to 600 kN

<i>ISO 14126 meth. 2</i>	<i>ISO 604</i>	<i>ASTM D 3410</i>	<i>ASTM D 695</i>	<i>ASTM D 6641</i>	<i>DIN 65375</i>	<i>JIS K 7076</i>
<i>prEN 2850</i>	<b><i>AITM 1-0008</i></b>	<i>Boeing BSS 7260 - type III and IV</i>	<i>SACMA SRM 1R-94</i>	<i>RAE-TR 88012 CRAG Method 400</i>	<i>RAE-TR 88012 CRAG Method 401</i>	



# Open hole and filled hole compression

Boeing and ASTM standards define a specific fixture to guide the specimen at both faces.

- The specimen is clamped in-between the two guide rails of this tool.
- The specimen is 36 mm large and the free length is 100 mm long.
- Older versions of the standards specified cut-outs for strain gages, recent versions did not specify strain measurement anymore.

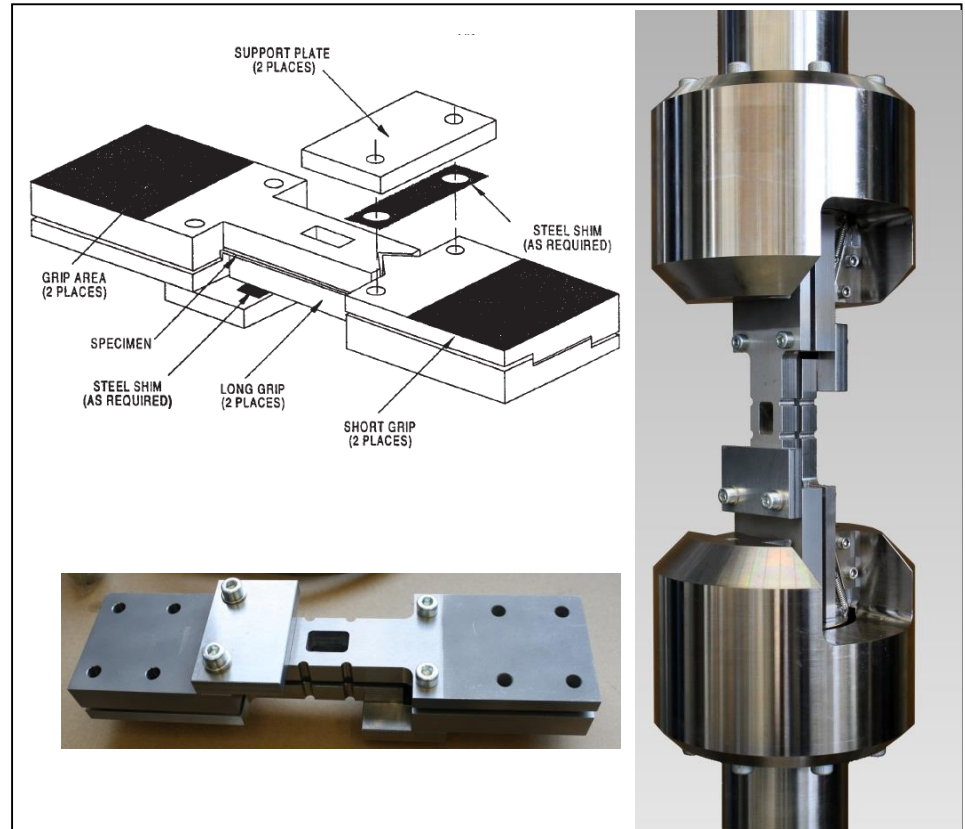
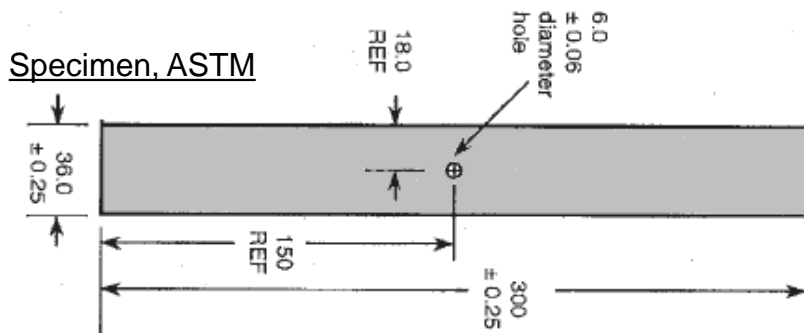

<i>prEN 6036</i>	<b>ASTM D 6484</b> <b>ASTM D 6742</b>	<b>Boeing BSS</b> <b>7260 - Type 1</b>	<i>AITM 1-0008</i>	<b>SACMA SRM</b> <b>3R-94</b>	<i>NASA RP 1092</i> <i>ST-4</i>	<i>CRAG Method</i> <i>402</i>	<b>Northrop</b> <b>NAI-1504C</b>
------------------	--	---	--------------------	----------------------------------	------------------------------------	----------------------------------	-------------------------------------

The Airbus AITM standard works with shorter specimen that can directly be clamped in guided grips. Zwick's HCCF fits ideally to this.



- The specimen is 32 mm large
- The initial distance between grips is 32 mm
- Strain gages of grid length  $\geq 3\text{mm}$  shall be used
- Bending and buckling is supervised by comparing the strain measured on both specimen faces. The allowed difference is 5%.
- The result is a “notch factor” that indicates the loss of strength compared to a plain specimen without hole (also called notch).

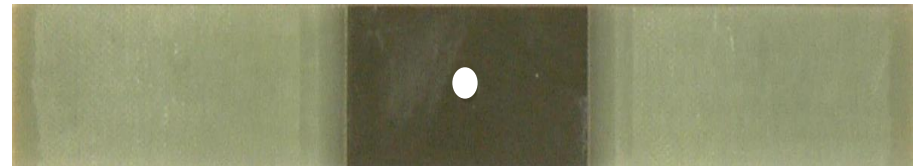

<i>prEN 6036</i>	<i>ASTM D 6484</i> <i>ASTM D 6742</i>	<i>Boeing BSS</i> <i>7260 - Type 1</i>	<b><i>AITM 1-0008</i></b>	<i>SACMA SRM</i> <i>3R-94</i>	<i>NASA RP 1092</i> <i>ST-4</i>	<i>CRAG Method</i> <i>402</i>	<i>NAI-1504C</i>
------------------	--	---	---------------------------	----------------------------------	------------------------------------	----------------------------------	------------------

Zwick covers all types of mechanical testing and thus more than 150 standards in the testing of advanced composites.

- Tensile
- Open hole and filled hole tensile
- **Compression after impact**
- Interlaminar shear strength
- Lap shear
- Rail shear
- Bearing strength
- Fracture mechanics
- Impact
- Hardness
- Creep
- Plain compression
- Open hole and filled hole compression
- Flexural tests
- In-plane shear
- V-notch beam shear (Iosipescu)
- Shear tests on plane specimens
- Fasteners testing
- Fatigue testing
- HDT

# Compression after impact

All equipments needed to characterize the damaging behavior of a composite by Compression After Impact tests (CAI) are available.



The instrumented falling weight tester HIT 230F is used to pre-damage the test piece under standard conditions.



A series of carefully pre-damaged test pieces is then tested in a testing machine with specific compression tools to determine the loss of compression strength by a known impact event.

ISO 18352	prEN 6038	ASTM D 7137 ASTM D 7136	DIN 65561	AITM 1.0010	Boeing BSS 7260 - type II	SACMA SRM 2R-94	CRAG method 403	NASA RP 1092 ST-1
-----------	-----------	----------------------------	-----------	-------------	---------------------------	-----------------	-----------------	-------------------

# Compression after impact

Pre-damaging by the instrumented HIT 230F allows exact process supervision and very simple and safe handling.

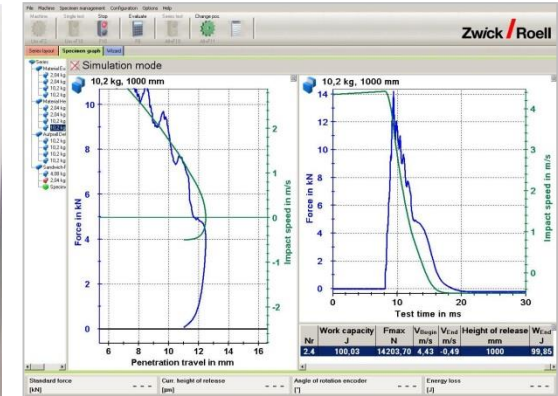
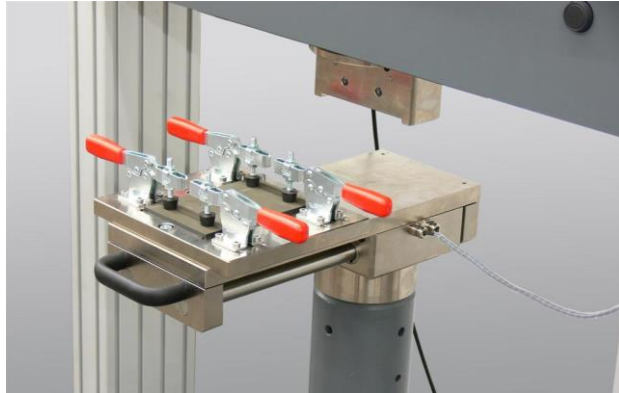

Specimens are clamped on a cut-out of: 76.2 by 127mm (ASTM, Boeing, SACMA, DIN), 75 x 125 mm (EN, Airbus) or 140 mm diameter (CRAG).

Only Airbus AITM requires clamping inside the open window of the steel base.

For ease of operation, the test-pieces are clamped outside the frame of the instrument and then pushed in place.

Different standards require different weights between 1kg and 8.16 kg to achieve the prescribed impact energy within a standardized speed range.

With a modular weight set, these weights can easily be changed.

The impact tup used is spherical with a diameter of (16 ± 0.5) mm.

testXpert II guides through the test procedure and directly shows the force-indentation curve and the consumed energy.

ISO 18352	prEN 6038	ASTM D 7137 ASTM D 7136	DIN 65561	AITM 1.0010	Boeing BSS 7260 - type II	SACMA SRM 2R-94	CRAG method 403	NASA RP 1092 ST-1
-----------	-----------	----------------------------	-----------	-------------	---------------------------	-----------------	-----------------	-------------------

The impact energy has to be adjusted to generate a “barely visible impact damage” (BVID). The highly sensitive load sensor provides detailed information about the damaging process.

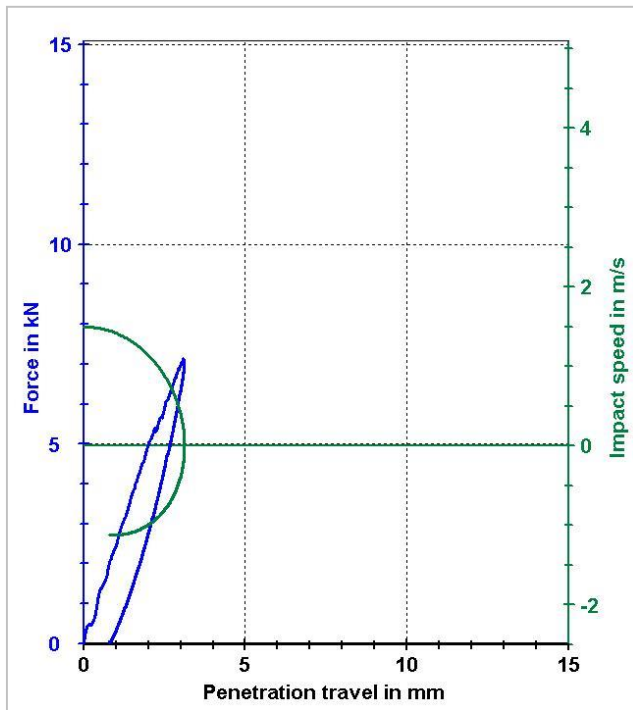

Low energy impact (11.5 J) mainly creates reversible elastic deformation.

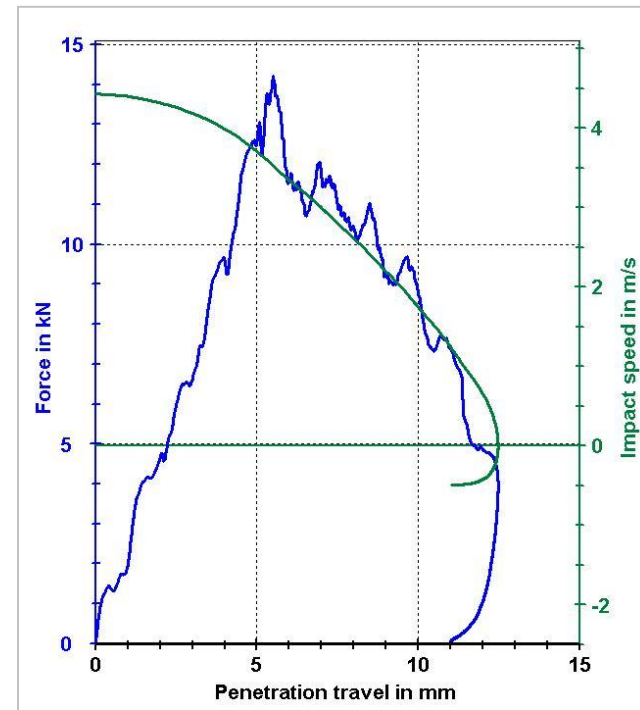

High energy impact (100 J) creates strong remaining damages, clearly visible on this curve.

ISO 18352	<i>prEN 6038</i>	ASTM D 7137 ASTM D 7136	DIN 65561	AITM 1.0010	Boeing BSS 7260 - type II	SACMA SRM 2R-94	CRAG method 403	NASA RP 1092 ST-1
--------------	------------------	----------------------------	--------------	-------------	------------------------------	--------------------	--------------------	----------------------

# Compression after impact

The pre-damaged specimens are then tested in specific tools in a compression test to determine the remaining strength.

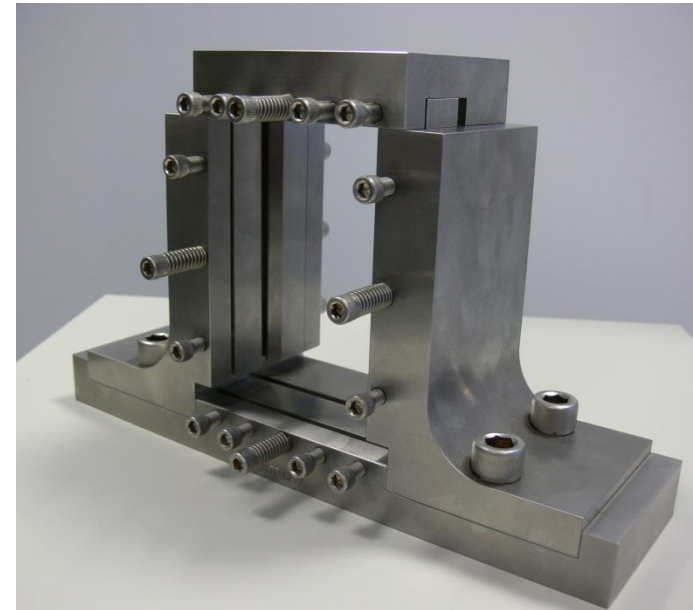
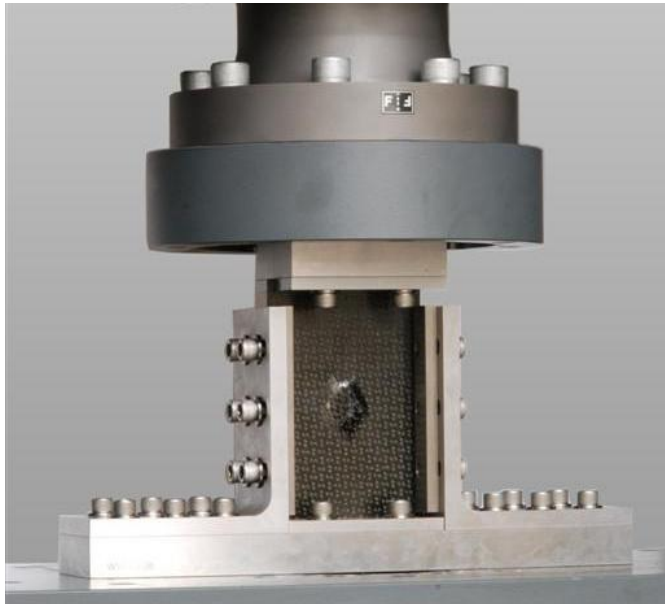

## Compression After Impact tools:

ASTM, Boeing, SACMA and DIN: all four sides are guided but not clamped.

ISO, EN and Airbus standard: Top and bottom are clamped, the lateral sides are guided with line-contact.

ISO 18352	prEN 6038	ASTM D 7137 ASTM D 7136	DIN 65561	AITM 1.0010	Boeing BSS 7260 - type II	SACMA SRM 2R-94	CRAG method 403	NASA RP 1092 ST-1
-----------	-----------	----------------------------	-----------	-------------	---------------------------	-----------------	-----------------	-------------------

Zwick covers all types of mechanical testing and thus more than 150 standards in the testing of advanced composites.

- Tensile
- Open hole and filled hole tensile
- Compression after impact
- Interlaminar shear strength
- Lap shear
- Rail shear
- Bearing strength
- Fracture mechanics
- Impact
- Hardness
- Creep
- Plain compression
- Open hole and filled hole compression
- **Flexural tests**
- In-plane shear
- V-notch beam shear (Iosipescu)
- Shear tests on plane specimens
- Fasteners testing
- Fatigue testing
- HDT



# Flexural tests

High quality tools, transducers and software are available for 3-point and 4-point flexural tests at ambient and in temperature chamber.

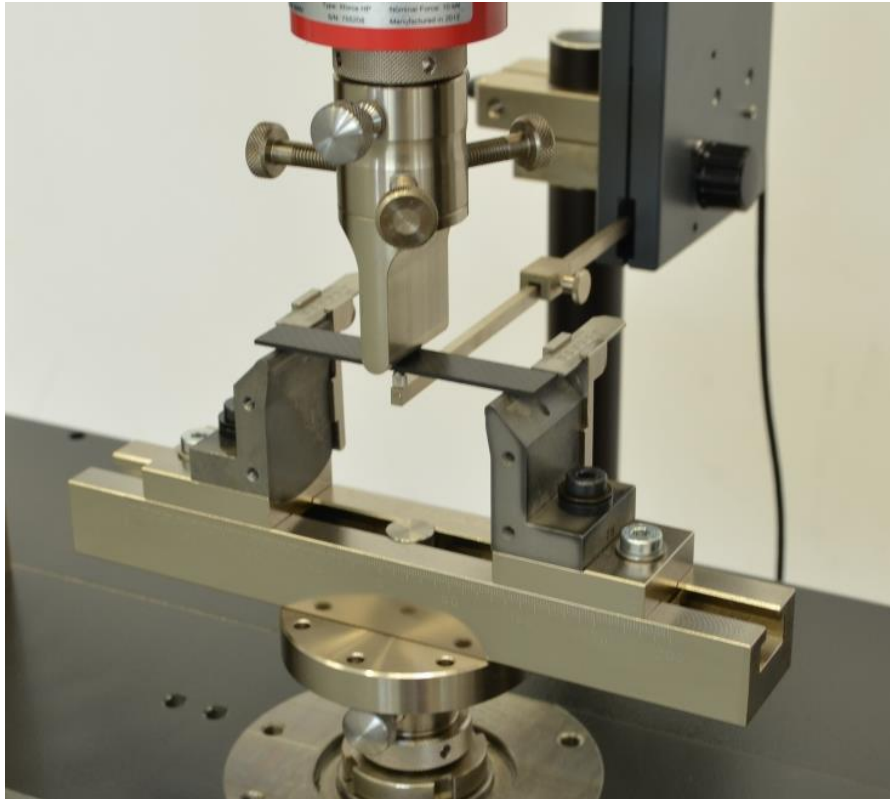

3-point flexural test

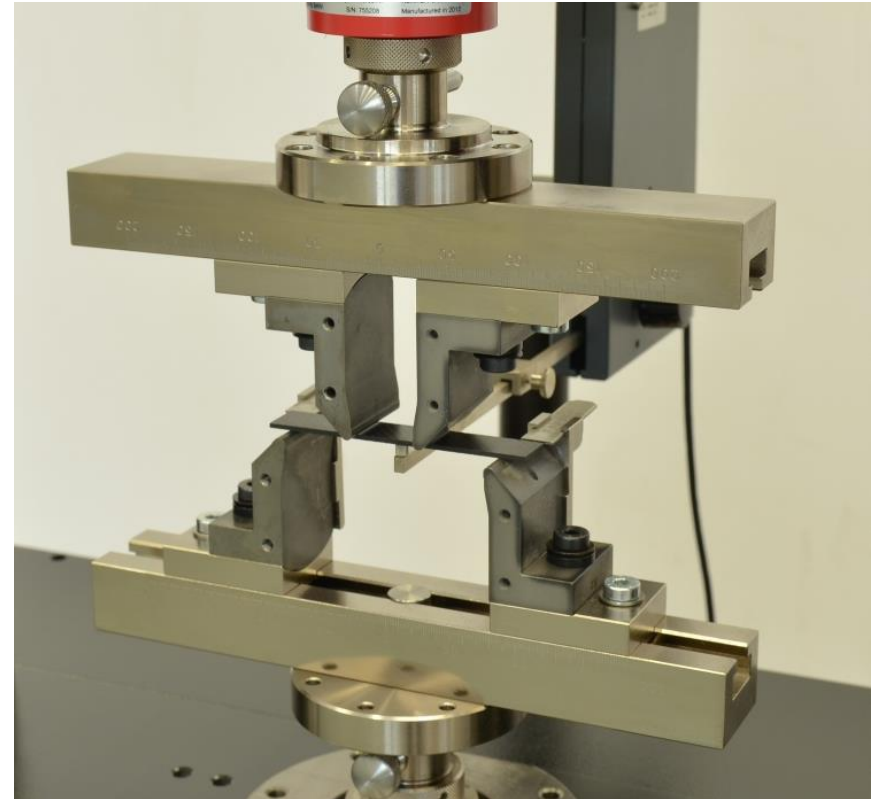

4-point flexural test

<i>ISO 14125</i>	<i>EN 2562</i>	<i>EN 2746</i>	<i>ASTM D 7264</i>	<i>ASTM D 790</i>	<i>ASTM D 4476</i>	<i>ASTM D 6272</i>	<i>CRAG Method 200</i>	<i>HSR/EPM-D- 003-93</i>
------------------	----------------	----------------	--------------------	-------------------	--------------------	--------------------	----------------------------	------------------------------

Zwick covers all types of mechanical testing and thus more than 150 standards in the testing of advanced composites.

- Tensile
- Open hole and filled hole tensile
- Compression after impact
- Interlaminar shear strength
- Lap shear
- Rail shear
- Bearing strength
- Fracture mechanics
- Impact
- Hardness
- Creep
- Plain compression
- Open hole and filled hole compression
- Flexural tests
- In-plane shear
- V-notch beam shear (Iosipescu)
- Shear tests on plane specimens
- Fasteners testing
- Fatigue testing
- HDT

Short Beam Shear (SBS) tests to assess the ILSS can be performed by using a sufficiently rigid 3-point bending fixture.



## Summary:

- The method does not supply a result being a real shear property as peak stresses near to the loading fin are present. The result is therefore called “Apparent Shear Stress”.
- Span-to-thickness ratio is short. A ratio of 4 or 5 is typical, giving a span of 10 mm for a 2mm specimen.
- No deflection measurement needed
- Exact span adjustment needed ( $\pm 0.3$  mm)
- Very exact centering of the loading nose needed
- Forces are significantly higher compared to 3-point flexural

<i>ISO 14130</i>	<i>EN 2377</i>	<i>EN 2563</i>	<i>ASTM D 2344</i>	<i>ASTM D 4475</i>	<i>JIS K 7078</i>	<i>SACMA SRM 8-88</i>	<i>CRAG method 100</i>
------------------	----------------	----------------	--------------------	--------------------	-------------------	---------------------------	----------------------------

A new ILSS fixture with easy-to-set support distance is available for testing laminates of variable thicknesses

Summary:

- Support-span to laminate thickness ratio is 4 or 5, depending upon the standard.
- Support span has to be calculated and set for each series of tests
- Fixture allows easy and centric setting of the correct support span
- Each support can be aligned individually
- No need for repeated alignment setting after change of support span.

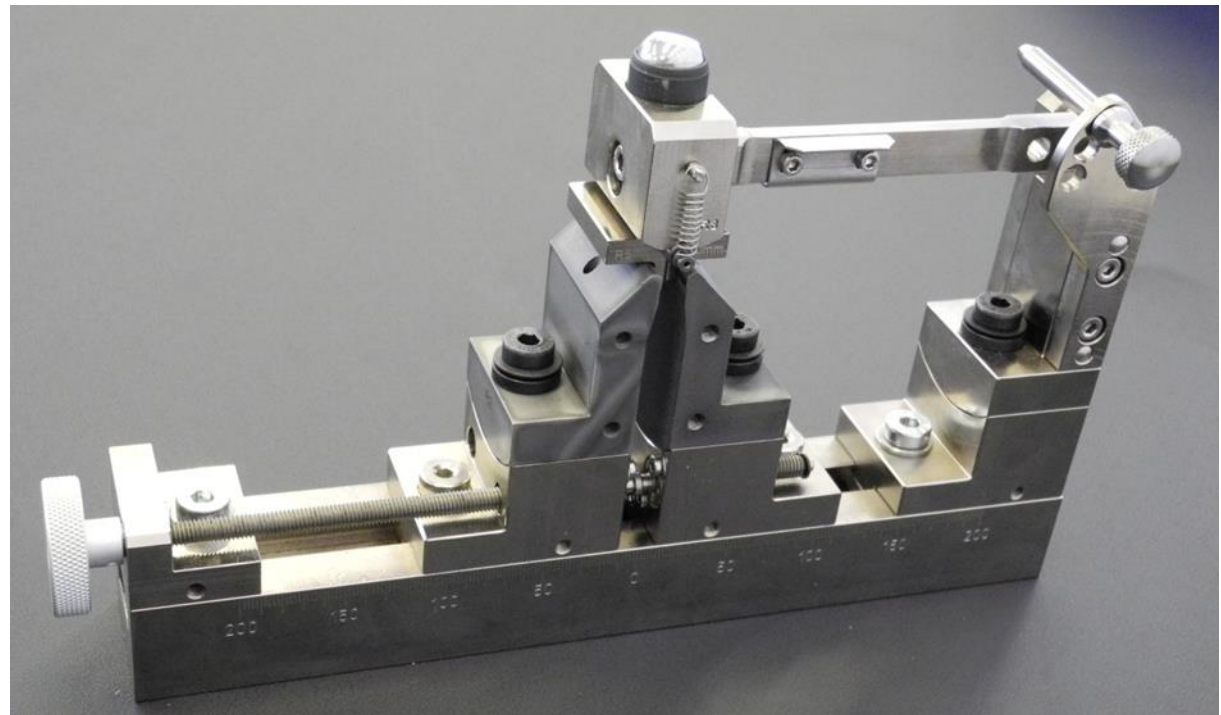

<i>ISO 14130</i>	<i>EN 2377</i>	<i>EN 2563</i>	<i>ASTM D 2344</i>	<i>ASTM D 4475</i>	<i>JIS K 7078</i>	<i>SACMA SRM 8-88</i>	<i>CRAG method 100</i>
------------------	----------------	----------------	--------------------	--------------------	-------------------	-----------------------	------------------------

Lap-shear tests are suited for comparative tests on adhesives, i.e. film or prepreg used for bonding laminate composite materials.



**Summary:**

- Horizontally adjustable grips are needed to test simple single lap shear specimen, i.e. wedge screw grips or pneumatic
- Slotted single lap shear specimen can be tested with simple symmetrically closing grips, i.e. wedge grips. The EN and the DIN method specify a support to prevent bending.
- Double lap shear specimen may always be tested with simple grips. Slotted lap shear specimen allow the same grip opening on both grips.
- The result is an in-plane the shear strength.

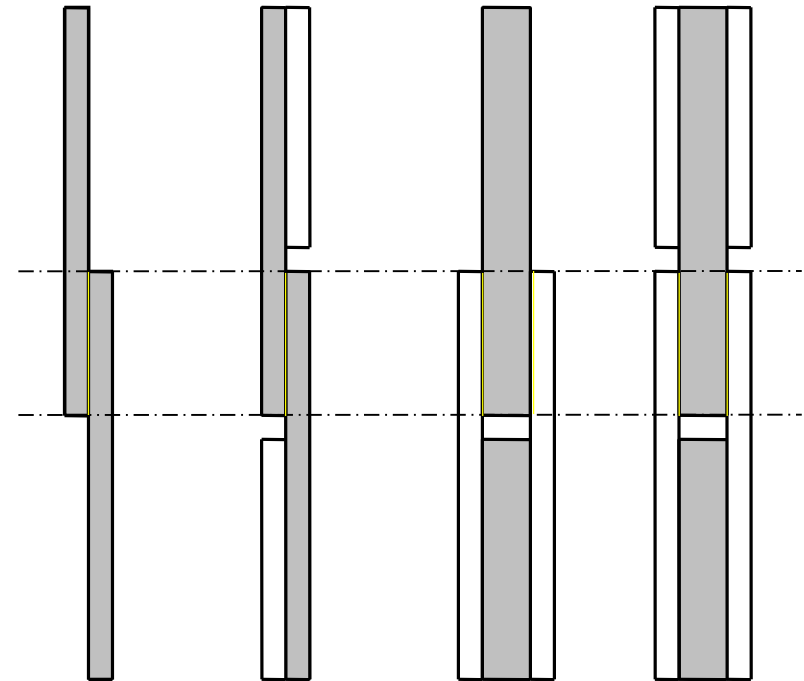

Single Lap Shear specimen    Double Lap Shear specimen  
 Simple    Slotted    Simple    Slotted

EN 2243-1	EN 2243-6	pr EN 6060	AITM 1-0019 QVA Z10-46-01 QVA-Z10-46-09	CRAG method 102	DIN 65148	ASTM D 3528	ASTM D 3846
-----------	-----------	------------	---	--------------------	-----------	-------------	-------------

One method to produce in-plane shear consists in performing a tensile or compression test under  $\pm 45^\circ$  to the fiber direction.

Summary:

- Specimen are cut from plates under  $45^\circ$  to the fiber direction
- Extension measurement in long and transverse direction by extensometer or strain gages needed.
- In-plane stress:  $\tau = F / (2 a h)$
- In-plane strain:  $\gamma_{12} = (\epsilon_x - \epsilon_y)$
- The shear modulus is calculated as a secant between the strain points 0.001 and 0.005
- Test method is not valid for deformations greater 5%.

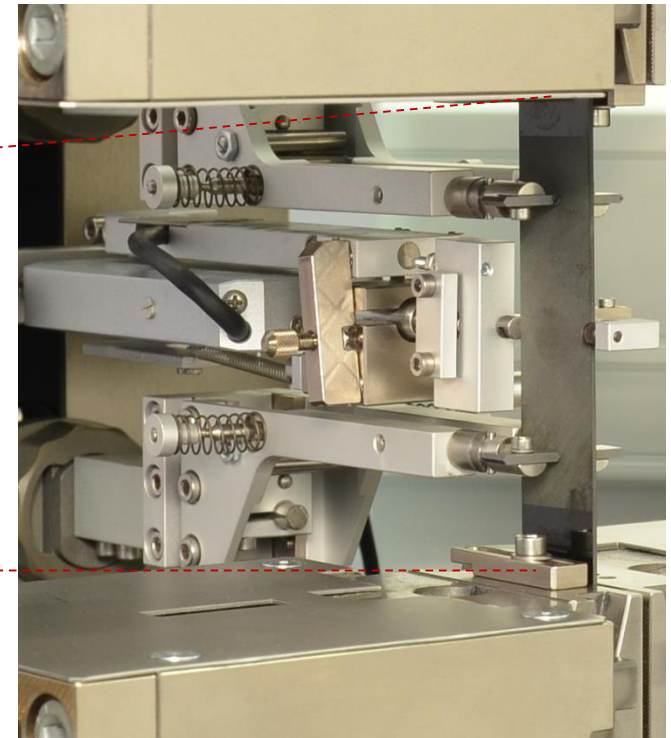
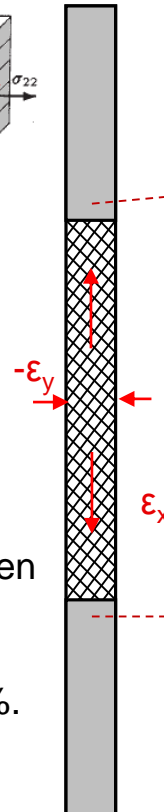
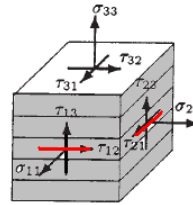

ISO 14129	prEN 6031	ASTM D 3518	AITM 1-0002	DIN 65466	JIS K 7079	SACMA SRM 7-94	CRAG method 101
-----------	-----------	-------------	-------------	-----------	------------	----------------	-----------------

The V-notched Rail shear test can be used to create both, in-plane or interlaminar shear and allows to evaluate any single of the six possible shear planes separately.

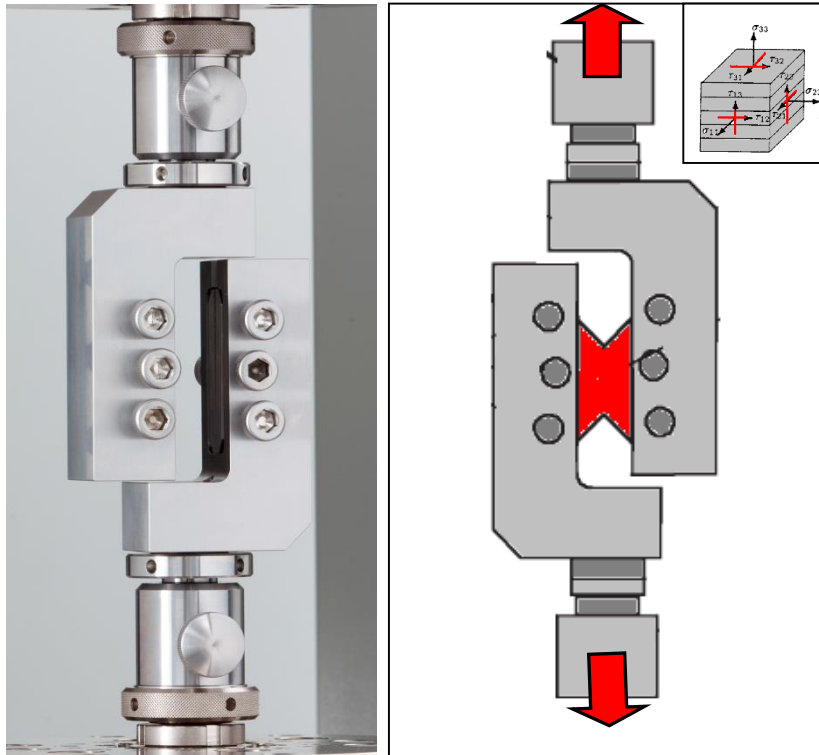

## Summary :

- Fibers shall be parallel or perpendicular to the loading axis
- Strain gages are placed in 45° direction in the shear plane
- Quite large shear surface compared to Iosipescu method
- Results are shear response, 0.2% offset stress, ultimate stress and strain, chord shear modulus
- Interlaminar shear and in-plane shear properties can be evaluated by this method.

ASTM D 7078

# V-notch beam shear (Iosipescu)

The Iosipescu or v-notch beam shear test creates a zone of pure shear in the specimen and allows to evaluate any single of the six possible shear planes separately.

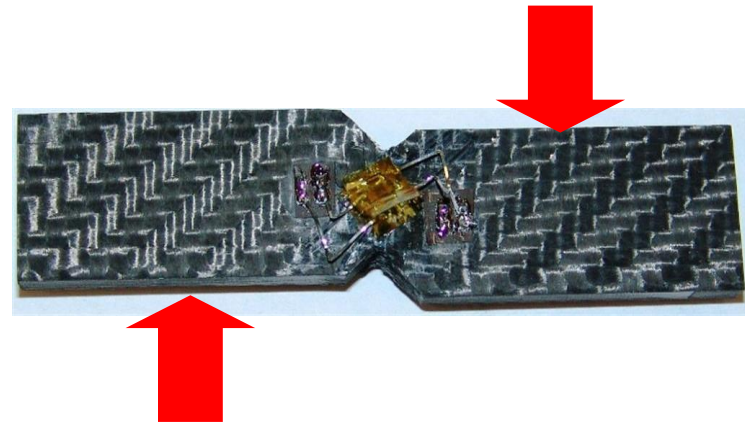
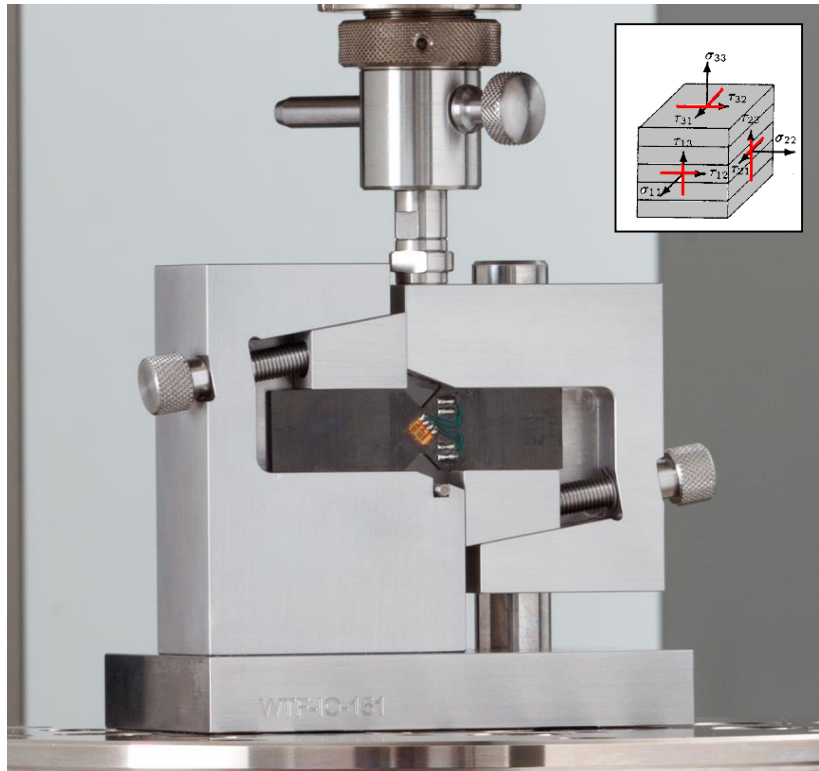

## Summary of the test method:

- For unidirectional high modulus fibers or woven fabric
- Fibers shall be parallel or perpendicular to the loading axis
- Strain gages are placed in  $45^\circ$  direction in the shear plane
- Results are shear response, 0.2% offset stress, ultimate stress and strain, chord shear modulus
- Interlaminar shear and in-plane shear properties can be evaluated by this method.

ASTM D 5379



Zwick covers all types of mechanical testing and thus more than 150 standards in the testing of advanced composites.

- Tensile
- Open hole and filled hole tensile
- Compression after impact
- Interlaminar shear strength
- Lap shear
- Rail shear
- **Bearing strength**
- Fracture mechanics
- Impact
- Hardness
- Creep
- Plain compression
- Open hole and filled hole compression
- Flexural tests
- In-plane shear
- V-notch beam shear (Iosipescu)
- Shear tests on plane specimens
- **Fasteners testing**
- Fatigue testing
- HDT

# Bearing strength

Standard test methods exist for different fastener configurations. The test serves to measure the bearing forces and bearing strain.

Summary:

- Procedure A is used for tensile
- Procedure B compression uses a similar support fixture as the Open / Filled hole Compression test
- Clamping by usual mechanic clamps as for tensile tests
- Macro extensometer can be used for bearing strain measurements.

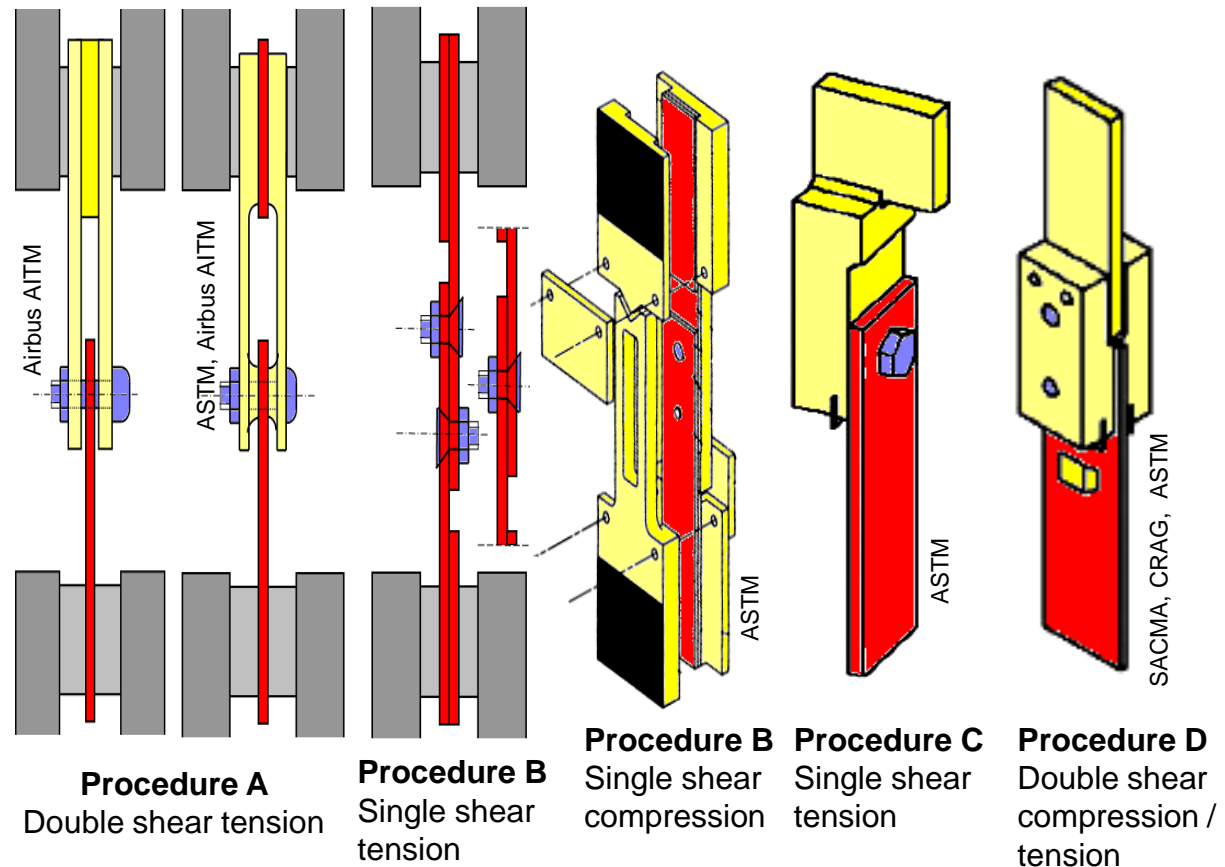

<i>ASTM D 5961</i>	<i>AITM 1.0009</i>	<i>prEN 6037</i>	<i>DIN 65562</i>	<i>TR 88012 CRAG method 700</i>	<i>SACMA SRM 9-89</i>	
--------------------	--------------------	------------------	------------------	---------------------------------	-----------------------	--

Zwick covers all types of mechanical testing and thus more than 150 standards in the testing of advanced composites.

- Tensile
- Open hole and filled hole tensile
- Compression after impact
- Interlaminar shear strength
- Lap shear
- Rail shear
- Bearing strength
- **Fracture mechanics**
- Impact
- Hardness
- Creep
- Plain compression
- Open hole and filled hole compression
- Flexural tests
- In-plane shear
- V-notch beam shear (Iosipescu)
- Shear tests on plane specimens
- Fasteners testing
- Fatigue testing
- HDT

Three different fracture modes describe the type of charging, “crack opening”, “in-plane shear” and “out of plane shear”. Mode I and Mode II are currently used for composites.

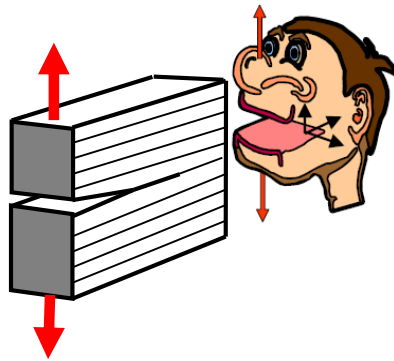

Mode I  
Crack Opening

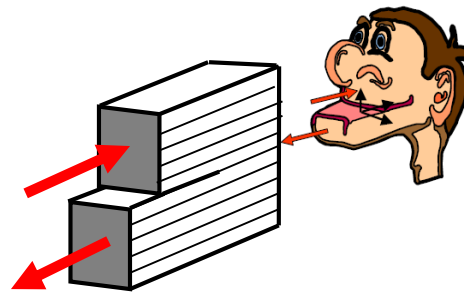

Mode II  
In-Plane Shear

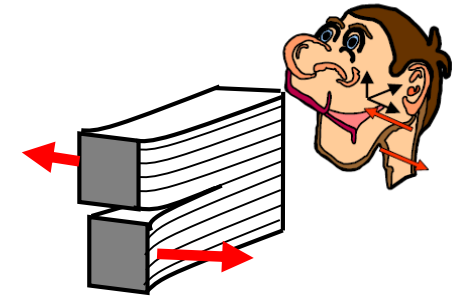

Mode III  
Out-of-Plane Shear

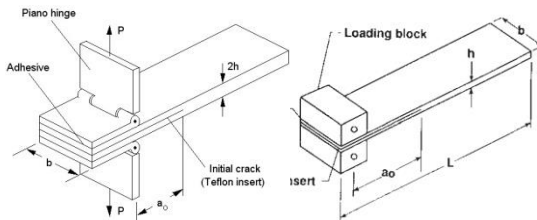

DCB  
Double Cantilever Beam

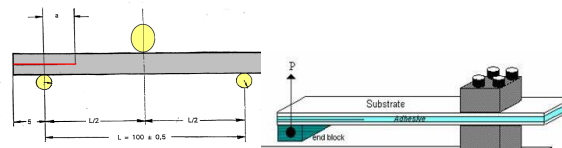

ENF - End  
Notch Flexure

C-ELS, End  
Loaded Split

No standardized specimen

The mode I fracture toughness energy calculation  $G_I$  for composites is based on the linear elastic theory (LEFM) .

DCB Specimen

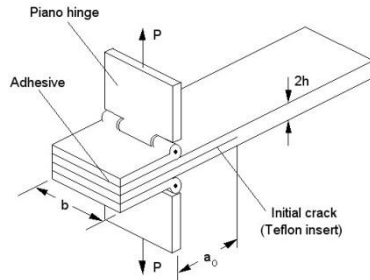

Summary:

- Crack opening is normally measured by the crosshead displacement. This displacement may be compensated for the frame stiffness (compliance compensation)
- Crack growth can visually be followed at both edges of the specimen. Alternatively, crack growth gages can be used.
- Only stable crack growth can properly be followed
- $G_{IC}$  is the released energy per unit of surface needed to propagate a crack
- Some standard require constitution of R-curves.

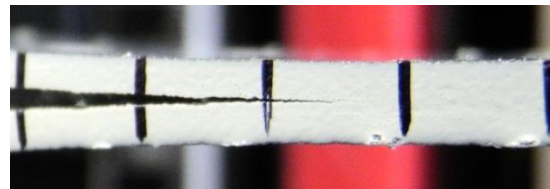
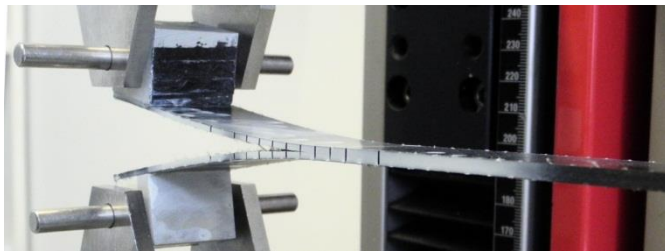
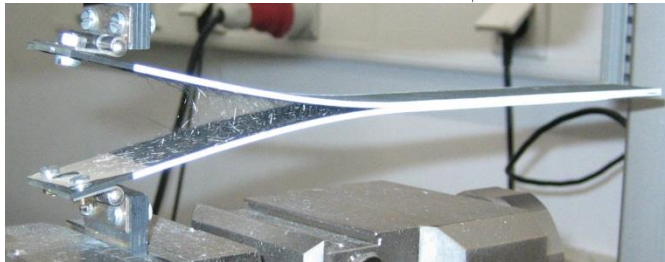

<i>ISO 15024</i>	<i>ASTM D 5528</i>	<i>AITM 1-0005</i> <i>AITM 1-0053</i>	<i>Boeing BSS</i> <i>7273</i>	<i>CRAG</i> <i>method 600</i>	<i>NASA method</i> <i>RP 1092 ST-5</i>	<i>ESIS TC 4</i>	<i>prEN 6033</i> <i>(withdrawn)</i>
------------------	--------------------	--	----------------------------------	----------------------------------	---	------------------	--

# Fracture toughness, $G_{II}$

The calculation of mode II fracture toughness energy release rate ( $G_{II}$ ) is based on force and deflection at the crack onset point.

- The test setup is standardized as 3-Point Bending.
- Specimen are ENF (End Notch flexure) in ASTM and ELS (End loaded split) in ISO.
- Deflection measurement can be performed by crosshead (with compliance compensation), or by a transducer placed at mid-span.
- The crack onset point is characterized by a maximum load point.
- After the test the specimen is cooled in liquid nitrogen and completely broken for inspection of the break surface.
- An alternative method is to use TCT (Transverse Crack Tension) specimen.

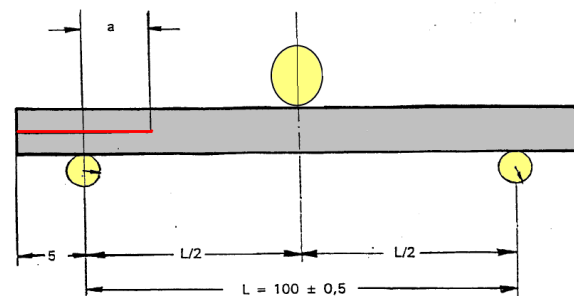
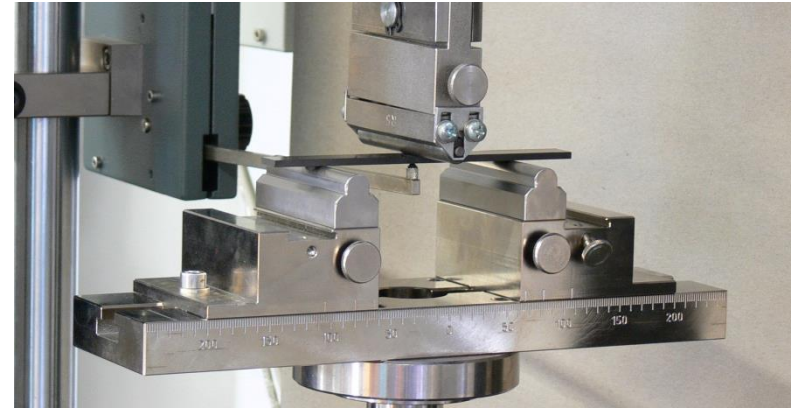

AITM 1-0006	Boeing BMS 8-276	ASTM D 7905	ISO 15114				prEN 6034 (withdrawn)
-------------	---------------------	-------------	-----------	--	--	--	--------------------------

# Fracture toughness, $G_{IIc} / G$

Mixed Mode Bending applies to unidirectional laminates. It combines mode I (opening) and mode II (shear by bending)

Specimen

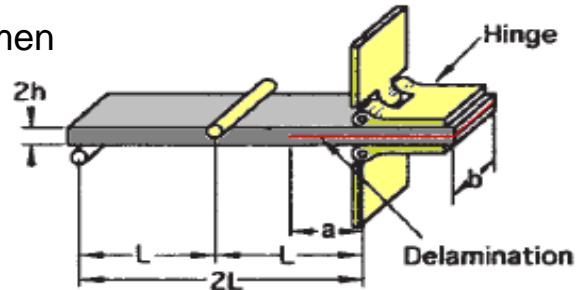

Fixture

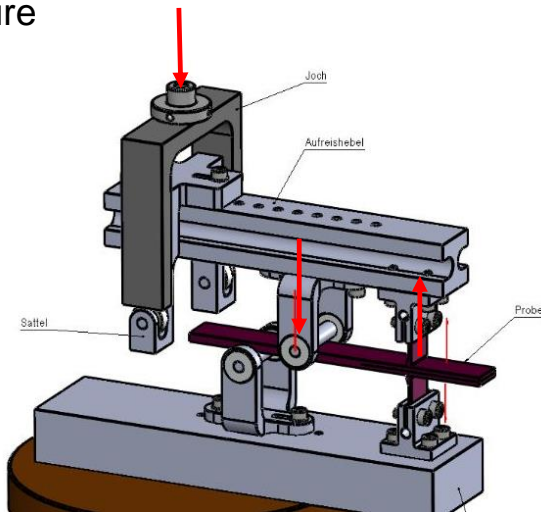

ASTM D 6671							
-------------	--	--	--	--	--	--	--

Crack propagation measurements become traceable and more comfortable by use of the motorized Video-Recording system.

- Enhanced traceability
- Repositioning of crack points after testing
- Modes I and II and mixed mode

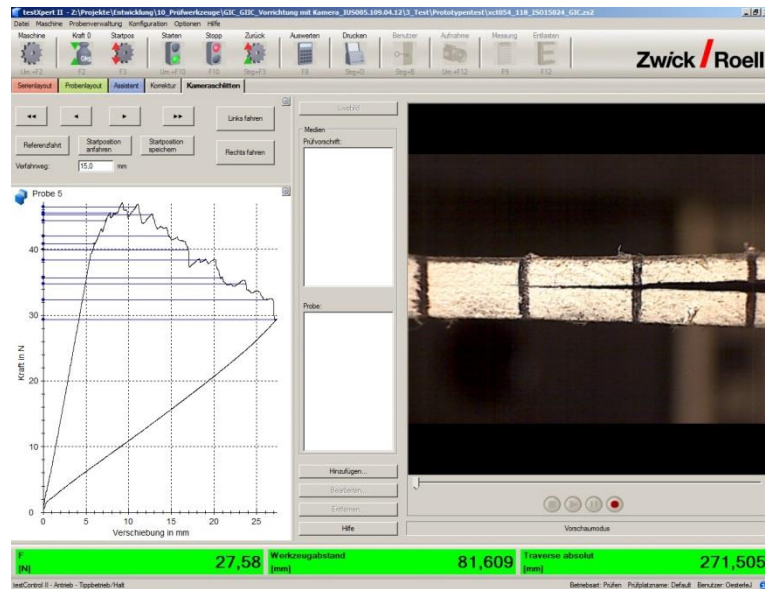



Applications of advanced composites

The supply chain

Test methods

Testing machines and instruments

Allround-Line are designed to meet highest requirements.



Table-top machines  
from 5 to 150 kN



Floor models are available with  
one or two workspaces



Capacities of up to 2000 kN with  
electro-mechanical drive system.

Electro-dynamic testing machines LTM 5 and LTM 10 are designed for fatigue tests.

- Capacity 5 kN or 10 kN (dynamic loading)
- Test frequencies up to 100 Hz (depending on stroke)
- Electro-dynamic linear drive system.
- Fatigue testing
- Parts, components and structural details
- Adhesives, glued connections
- Low energy consumption
- Low running costs
- Absence of hydraulic oil
- 3 different cooling options  
(air, external chiller, cooling water connection)



LTM 10 – dynamic with electrical drive system

# Dynamic testing

Servo-hydraulic Testing Machines are used for fatigue testing, especially at higher loads.



Tabletop machine for forces up to 25 kN



Floor standing machine HA, capacities from 50 to 250 kN



Floor standing machines HB, capacities from 50 to 2500 kN.

## Materials testing machines for combined tensile and torsion.



Z050 Allround, torque drive 200 Nm

Drive system for pure torsion and combined tension-torsion applications:

- Torque drives with capacities of 100 Nm to 2000 Nm available.
- Accurate torque cells to measure the torsion moment
- High resolution angle transducer
- Perfect synchronization between force-, torque, travel and angle measurement channels.

# Temperature chambers

## Testing in hot and cold conditions.

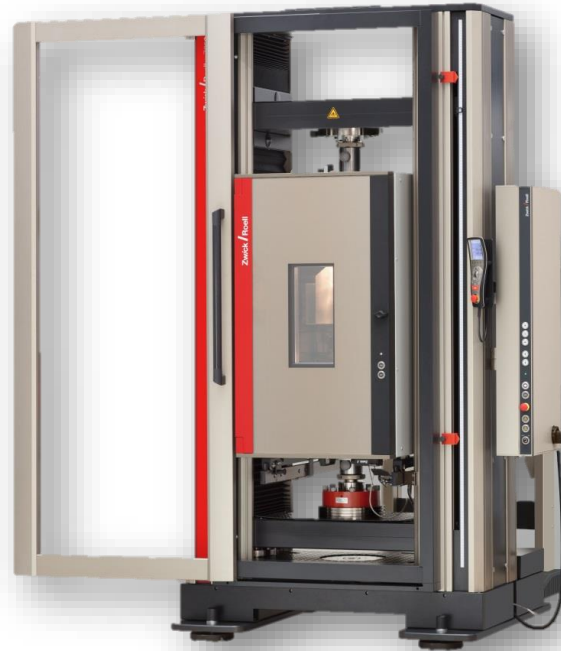

- Accurate temperatures between - 80 and +250 °C
- Guide rails for easy change between ambient and temperature conditions
- Sliders to pull back the chamber without dismounting the specimen holders
- Slit opening for extensometers

# Modular testing system, 100 and 250 kN

Zwick has developed a modular system for non-ambient testing, covering 21 methods and about 120 test standards.



Tensile, OHT, FHT, Load Bearing, Lap Shear, In-Plane Shear

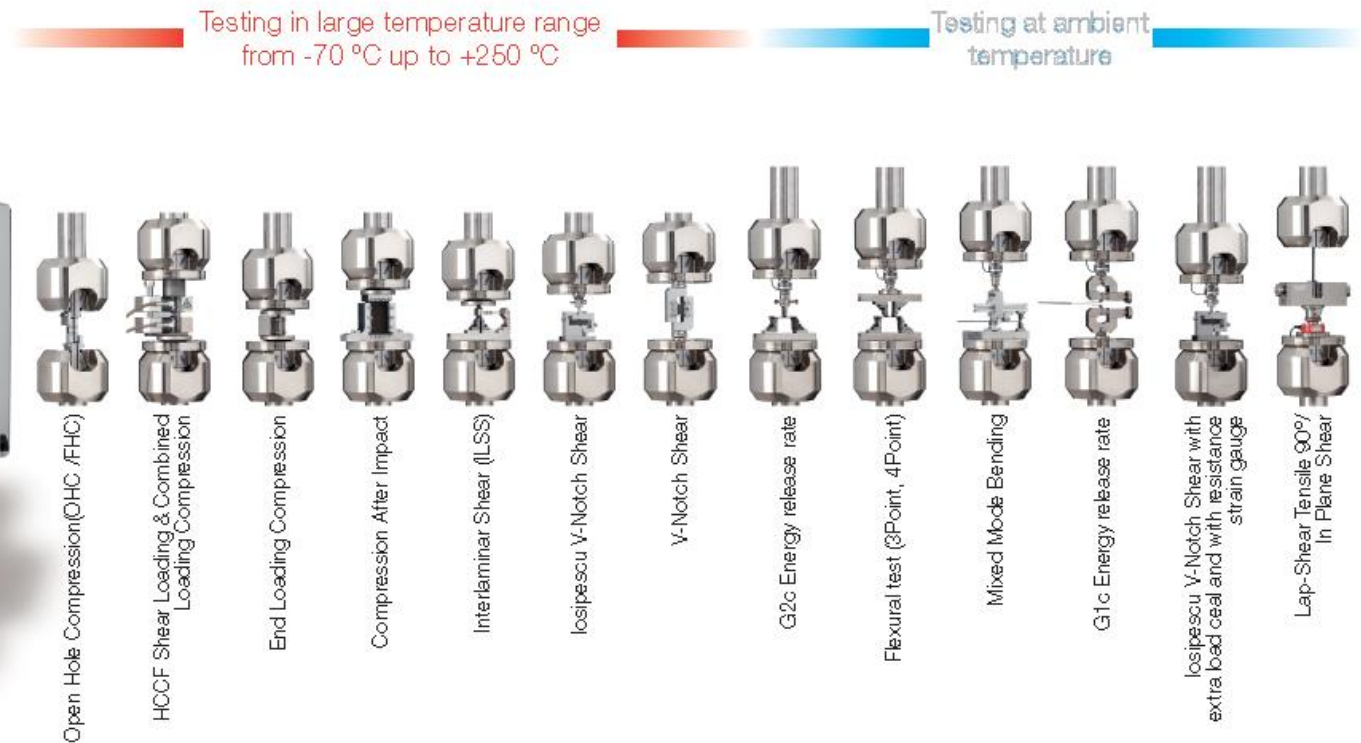

# The “two-in-one machine”

The lateral test area of this machine offers the functionality of a second machine and avoids the change of heavy grips.

- **Central work space for 250 kN capacity**
  - Tensile, FHT, OHT, compression, FHC, OHC and CAI tests
  - Several types of shear tests
  - Load bearing tests
- **Lateral work space for maximum 50 kN capacity**
  - Lap shear, 90° tensile
  - $\pm 45^\circ$  shear (IPS)
  - Iosipescu and V-notch shear
  - Short beam shear (ILSS)
  - GIC, GIIC, Mixed mode bending
  - Flexural tests
- Temperature testing in both test areas possible
- Protective housing for both test areas
- Use of extensometers in both test areas
- Small footprint compared to two machines





# Modular testing system, 600 kN

The modular system is now also available for forces up to 600 kN.

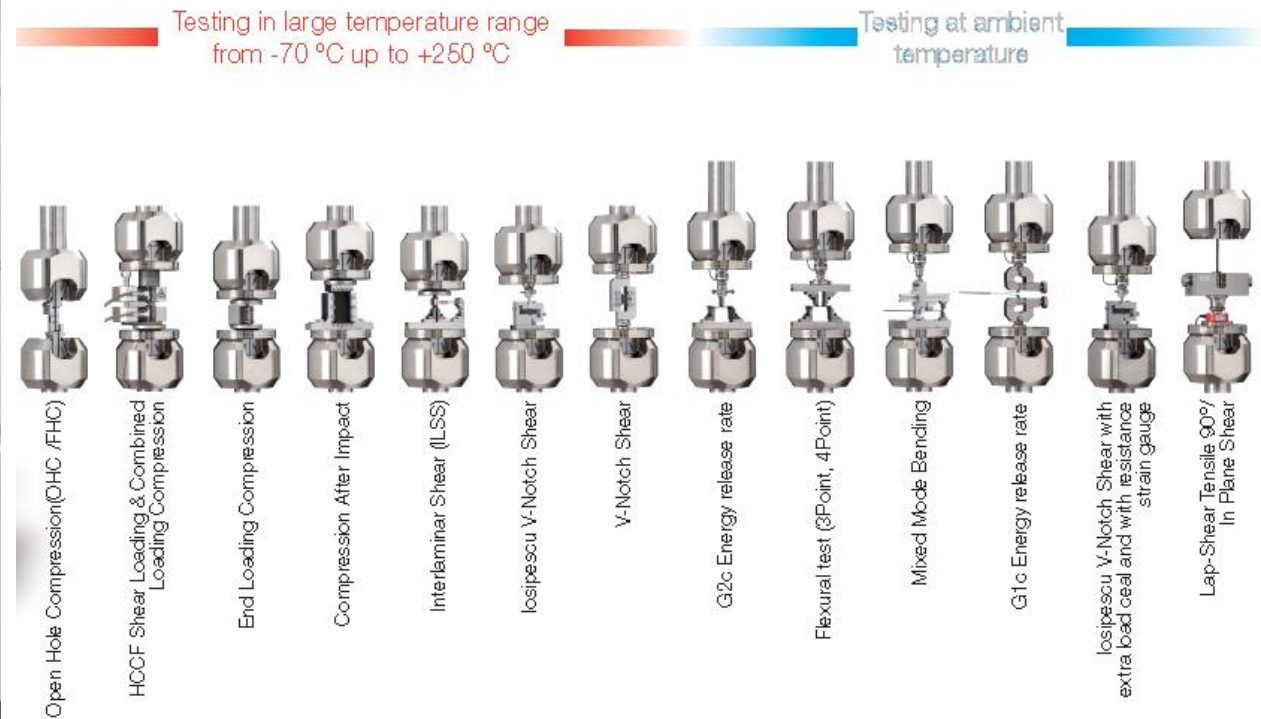

## Perfect alignment is important for accurate test results



- Smallest errors in angularity and concentricity result in significant bending within the test piece.
- Several standards (ASTM E 1012, ISO 23788) and Nadcap Audit Criteria 7122 provide guidance and set tolerances.
- Typical allowed bending limits for composites are 8 % in tensile and 6% in compression.

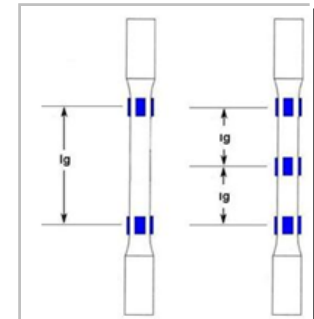
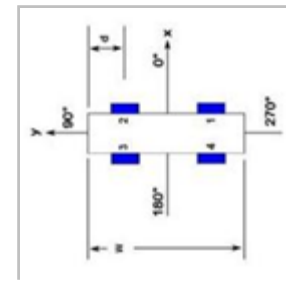

Pre-configured set-top boxes for typical types of strain gage connections are available.



- Prepared for 120  $\Omega$  and 350  $\Omega$
- Potentiometer for zero adjustment
- 4 wires cabling for half bridge
- Possible to connect 2 wires  $\frac{1}{4}$  bridge
- Possible to connect 3 wires  $\frac{1}{4}$  bridge
- Bridge-types with supply voltage measurement are possible
- Welding points prepared for other bridge resistances
- Switch to protect for short circuits during welding



## Zwick offers a bi-axial extensometer for composites testing

- For tensile and In-Plane-Shear (IPS) tests.
- Modulus, Poisson ratio, Shear strain
- Temperature range :  $-70^{\circ}\text{C}$  to  $+175^{\circ}\text{C}$
- Gage length: 25 mm
- Accuracy classes 0.5 and 1

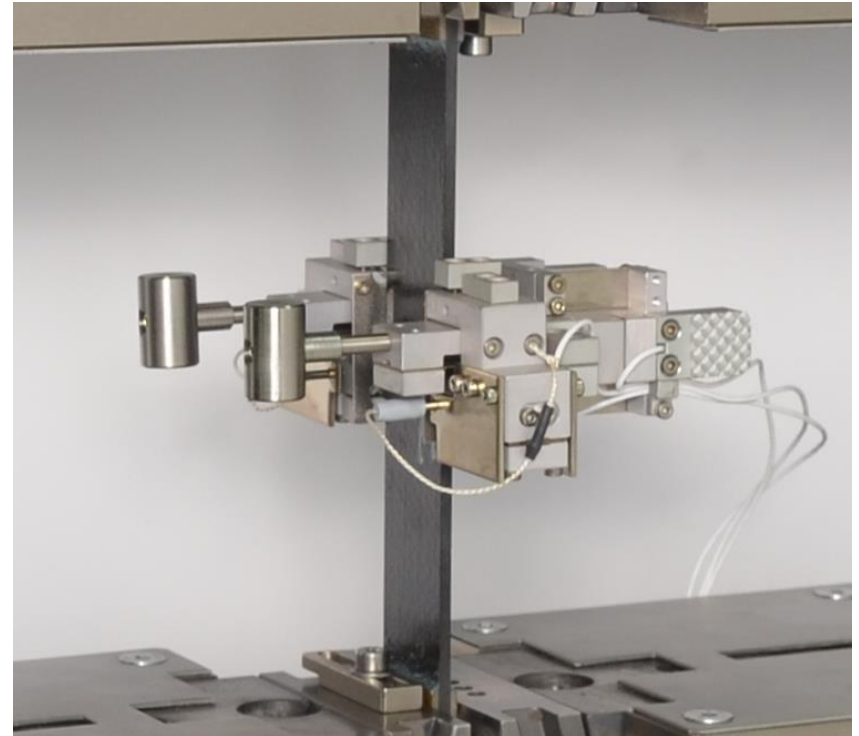

The automatic incremental makroXtens extensometer provides accurate modulus measurement.



## Technical data:

- Range: 75 mm to 160 mm
- Resolution: 0,12  $\mu\text{m}$  to 0,6  $\mu\text{m}$
- Accuracy: class 0,5 to ISO 9513
- Gage length: 10 to 205 mm
- Measuring system: incremental - optical
- Motorized feeler arms
- Rotatable knife edges for break measurement
- Crash sensor for secure operation
- Optional: motorized gage length set

# New videoXtens HP

The optical extensometer videoXtens HP achieves accuracy grade 0.5 and can be used for tensile modulus measurements.

Key features are:

- Double camera system
- Adaptable tunneling
- Integrated LED lightning
- Resolution down to 0.25 microns
- Large field of view (128 or 145 mm)



Benefits

- Reliable measurements for many materials, including plastics
- Insensitive to environmental conditions
- Fulfils ISO 527 modulus requirements.

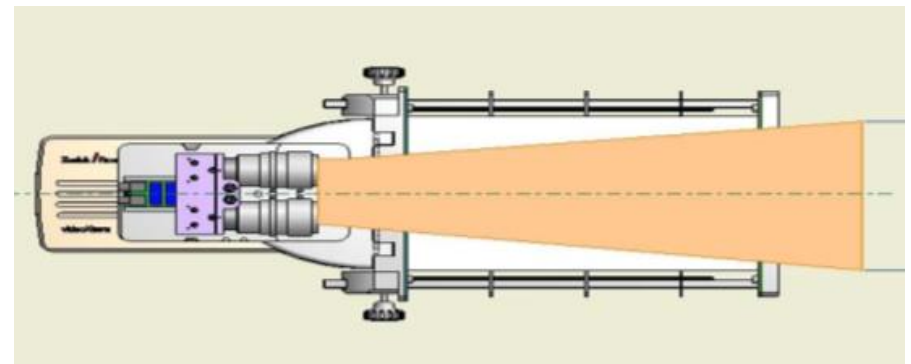

The videoXtens HP achieves a measurement quality which is close to that of approved mechanical extensometers like the makroXtens.

## Optic

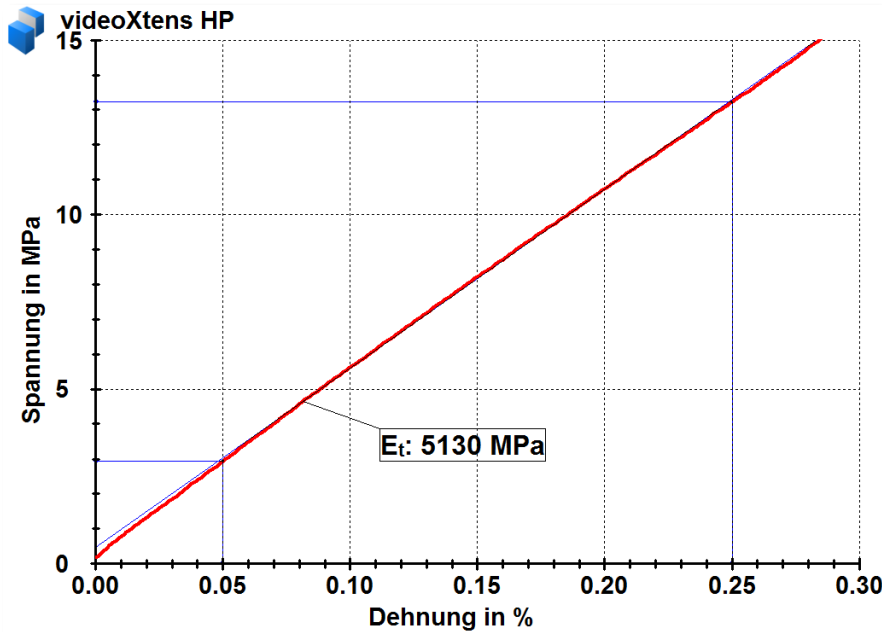

Measurement curve, optical videoXtens HP

## Mechanic

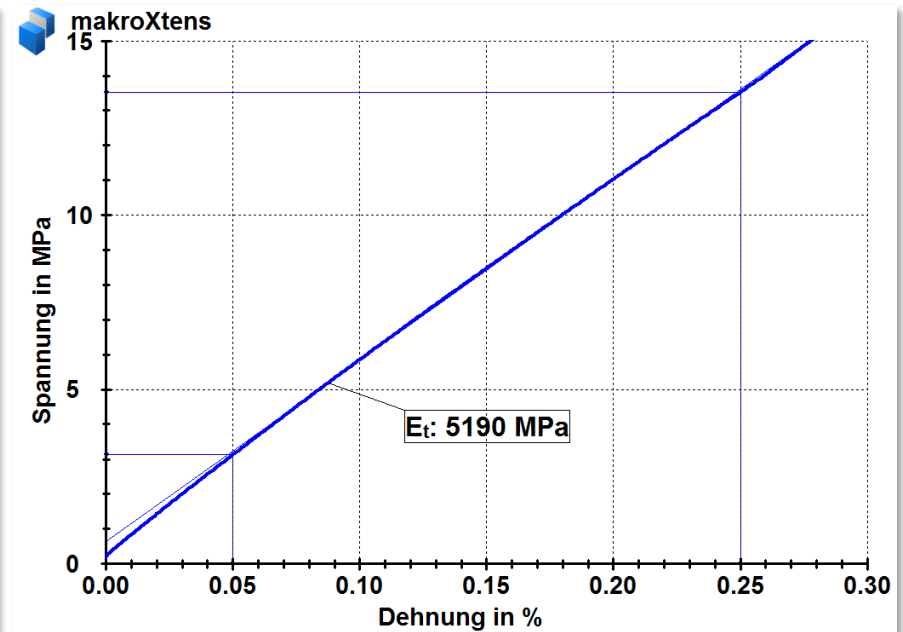

Measurement curve, mechanical makroXtens

Several types of optical and mechanical Zwick extensometers fulfill demanding requirements

## Optical



videoXtens HP

## Mechanical

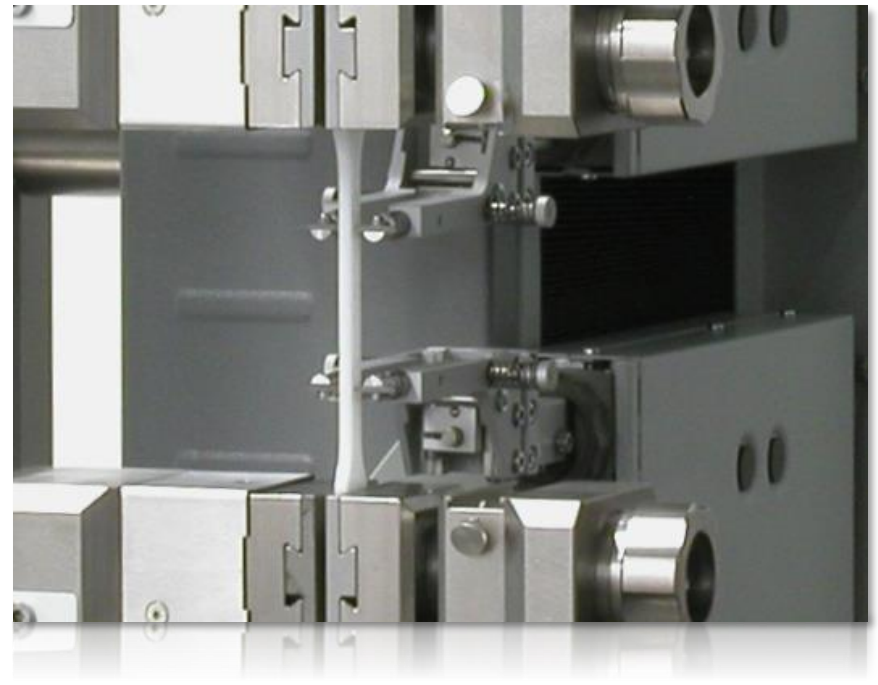

multiXtens, makroXtens, clip-on



# Product range

Zwick can offer a large range of grips, fixtures and solutions.





Zwick brings testing of composites to an industrial level of safety, reliability, ease of operation and automation.

- High quality testing machines ranging to capacities of more than 1000 kN.
- Comprehensive range of grips and tools, covering all current test methods
- HCCF, the new Hydraulic Composites Compression Fixture covering several test methods in one.
- The largest range of digital mechanical and optical extensometers
- The world leader in automation of mechanical testing
- *testXpert*<sup>®</sup> III, the intelligent software

